

HIAB 175 Basic data

Technical data

	175-1	175-2	175-3	175-4	175-5
Max. lifting capacity (kNm)	168	163	156	151	148
Outreach - hydraulic extensions (m)	6.2	8.0	10.0	12.1	14.1
Outreach - manual extensions (m)	-	14.2	16.3	18.5	18.4
Outreach / lifting capacity (m / kg)	2.3 / 6500	2.3 / 6500	2.3 / 6300	2.3 / 6200	2.3 / 6000
	4.5 / 3790	4.5 / 3700	4.5 / 3530	4.5 / 3420	4.5 / 3300
	6.1 / 2780	6.2 / 2640	6.2 / 2490	6.2 / 2380	6.2 / 2300
	-	7.8 / 2080	8.0 / 1870	8.0 / 1750	8.0 / 1690
	-	-	9.8 / 1500	9.9 / 1370	9.9 / 1300
	-	-	-	11.8 / 1100	11.8 / 1050
	-	-	-	-	13.8 / 890
Slewing angle	406°	406°	406°	406°	406°
Height in folded position (mm)	2265	2265	2265	2265	2265
Width in folded position (mm)	2451	2451	2451	2487	2489
Installation space needed (mm)	890	890	890	890	990
Weight - "standard" crane without stabilizer (kg)	1930	2070	2220	2350	2460
Weight - stabilizer equipment (kg)	238 - 380	238 - 380	238 - 380	238 - 380	238 - 380

HIAB 175-5

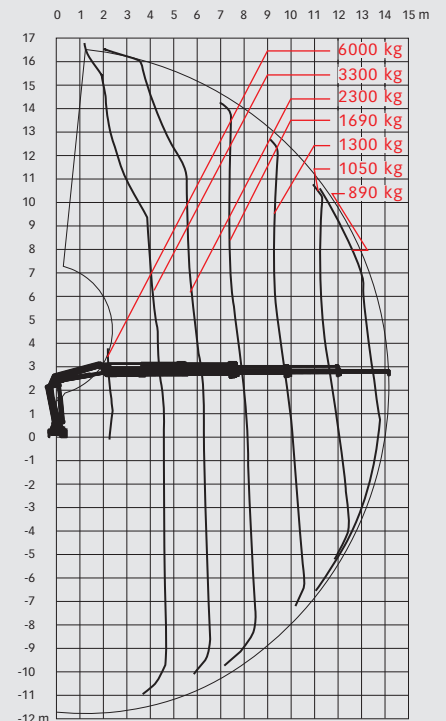
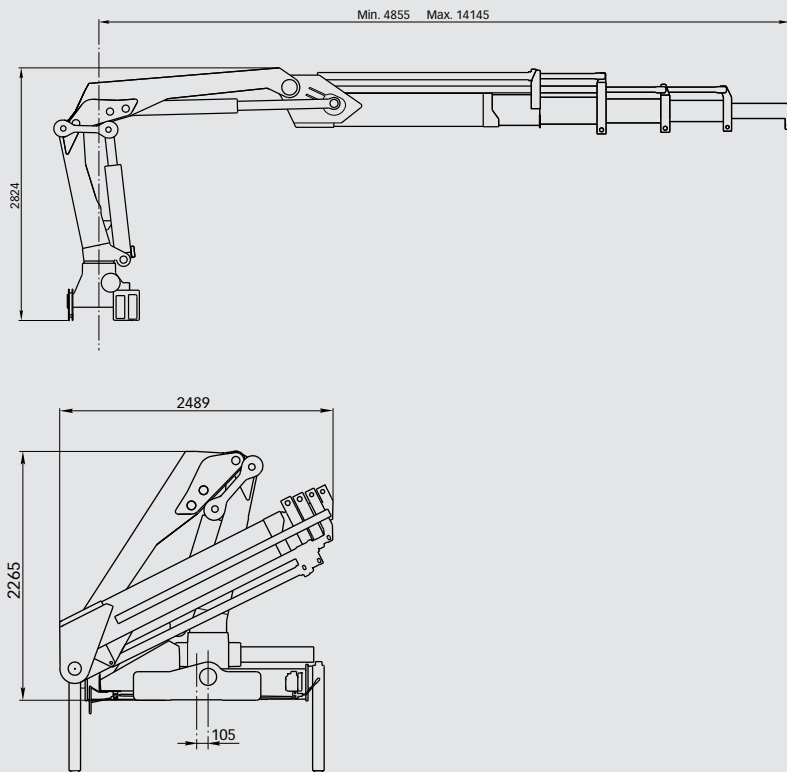

Disclaimer

Hiab cranes have been built to meet the highest standards of safety and service life and has been thoroughly tested. Strength calculations for this model have been carried out in accordance with DIN 15018. Hiab's certified Quality Assurance System complies with the ISO 9001. Some of the items in our literature may be extra equipment. Certain applications may require an official permit. We reserve the right to change technical specifications without prior notice. Hiab cranes produced for EU-countries are CE-marked and comply with the European Standard EN 12999.